



SOLUTIONS SECURING YOUR WORLD

KEY FEATURES

- 2MP Dome Day/Night Vandal proof Camera
- Ultra 265,H.265, H.264, MJPEG
- 120dB Optical WDR
- Smart IR, up to 30m IR distance
- 2.8~12mm motorised drive
- Triple streams
- ONVIF Conformance
- IK10
- IP67

SPECIFICATIONS

Description	2 Megapixel Vandal-proof Network Dome Camera	
Camera	Image Sensor	1/2.8", 2.0 megapixel, progressive scan, CMOS
	Lens	2.8 ~ 12mm, automatic focusing and motorized zoom lens
	Angle of View(H)	94.0° ~ 28°
	Angle of View (V)	56.7°~14.4°
	Angle of View (O)	122.2°~34.4°
	Adjustment angle	Pan: 0°~360°, Tilt: 0°~90° & Rotate: 0°~360°
	Shutter	Auto/Manual, 1~ 1/100000s
	Minimum Illumination	Colour: 0.001Lux (F1.6, AGC ON) 0Lux with IR on
	Day/Night	IR-cut filter with auto switch (ICR)
	Digital noise reduction	2D/3D DNR
	IR Range	Up to 30m
	WDR	120dB
	Video	Video Compression
Frame Rate		Main Stream: 2MP (1920*1080), Max 30fps; Sub Stream: 2MP (1920*1080), Max 30fps; Third Stream: D1 (720*576), Max 30fps
HLC/BLC		Supported
ROI/Privacy mask		Up to 8 areas
Audio	Audio Compression	G.711
Storage	Edge Storage	Micro SD, up to 256 GB
Network	Protocols	IPv4, IGMP, ICMP, ARP, TCP, UDP, DHCP, PPPoE, RTP, RTSP, RTCP, DNS, DDNS, NTP, FTP, UPnP, HTTP, HTTPS, SMTP, 802.1x, SNMP, QoS
	Compatible Integration	ONVIF (Profile S, Profile G, Profile T), API
Interface	Audio I/O	Input: impedance 35kΩ; amplitude 2V [p-p], Output: impedance 600Ω; amplitude 2V [p-p]
	Network	1x RJ45 10M/100M Base-TX Ethernet
General	Power	DC 12V±25%, PoE (IEEE 802.3af)
		Power consumption: Max 7.2W
	Operating Conditions	-40°C ~ 60°C (-40°F ~ 140°F), Humidity: ≤95% RH (non-condensing)
	Ingress Protection Level	IP67
	Vandal Resistant	IK10
	Dimensions	Ø148 x 111.3mm (Ø5.8" x 4.4")
Weight	0.92kg (2.0lb)	

ACCESSORIES



FCM-ND242
False Ceiling mount



WM-ND242
Wall mount



JB-ND242
Junction Box

DIMENSIONS

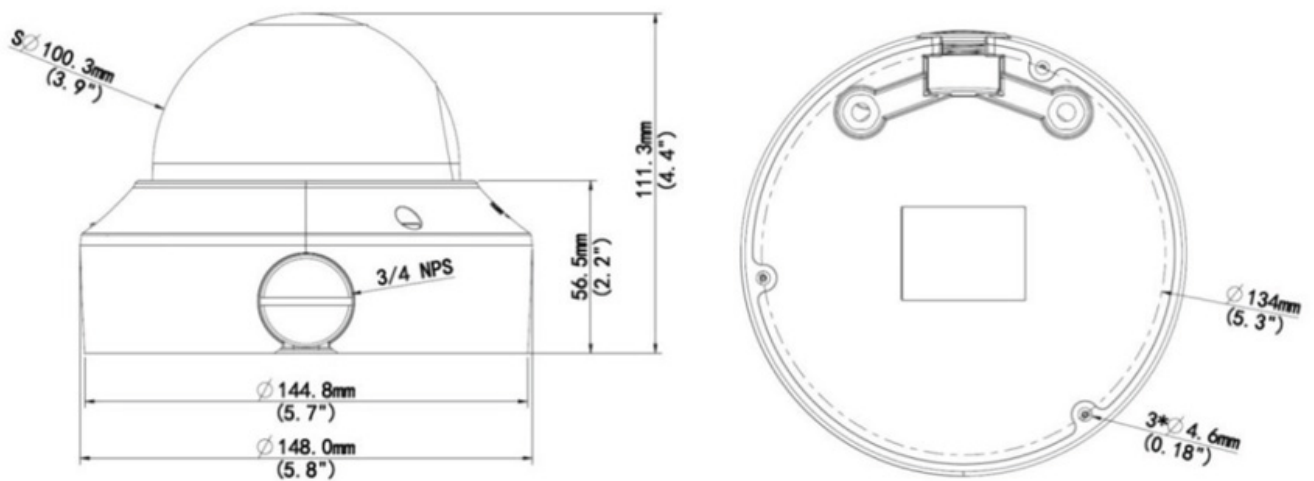

PARTCODE

NV-ND222Z

DESCRIPTION

2MP, Ultra 265/H.265, 2.8~12mm Motorised dome, 120 dB WDR, 30m IR, IK10, IP67.

UAE Address:
P3-Hamriyah Business Centre
PO Box 50235
Hamriyah Free Zone - Sharjah - UAE.
E-mail: info@networkvideosolutionsfze.com
Tel : +97148828919