



# TG-ND242Z



**SOLUTIONS SECURING YOUR WORLD**

## KEY FEATURES

- 4MP Bullet Day/Night Vandal proof Camera
- Smart IR, up to 30m IR distance
- Up to 120dB Optical WDR
- 2D/3D DNR(Digital Noise Reduction)
- Ultra 265,H.265, H.264, MJPEG
- Triple streams
- ROI (Region of Interest)
- ONVIF Conformance
- IP67

# SPECIFICATIONS

<b>Description</b>	4 Megapixel Vandal-proof Network Dome Camera	
<b>Camera</b>	Image Sensor	1/3", 4.0 megapixel, progressive scan, CMOS
	Lens	2.8 ~ 12mm, AF automatic focusing and motorized zoom lens
	Angle of View(H)	91.0° ~ 27°
	Angle of View (V)	54.4° ~ 13.7°
	Angle of View (O)	118.3° ~ 33.2°
	Adjustment angle	Pan: 0°~360°, Tilt: 0°~90° & Rotate: 0°~360°
	Shutter	Auto/Manual, 1~ 1/100000s
	Minimum Illumination	Colour: 0.005Lux (F1.4, AGC ON) 0Lux with IR
	Day/Night	IR-cut filter with auto switch (ICR)
	Digital noise reduction	2D/3D DNR
	IR Range	Up to 30m
	Defog	Digital Defog
	<b>Video</b>	Video Compression
Frame Rate		Main Stream: 4MP (2592*1520), Max 20fps; 4MP (2560*1440), Max 25fps; 3MP (2048*1520), Max 30fps; Sub Stream: 2MP (1920*1080), Max 30fps; Third Stream: D1 (720*576), Max 30fps
Motion Detection		Up to 4 areas
ROI		Up to 8 areas
<b>Audio</b>	Audio Compression	G.711
<b>Storage</b>	Edge Storage	Micro SD, up to 256 GB
<b>Network</b>	Protocols	IPv4, IGMP, ICMP, ARP, TCP, UDP, DHCP, PPPoE, RTP, RTSP, RTCP, DNS, DDNS, NTP, FTP, UPnP, HTTP, HTTPS, SMTP, 802.1x, SNMP, QoS
	Compatible Integration	ONVIF (Profile S, Profile G, Profile T), API
<b>Interface</b>	Audio I/O	Input: impedance 35kΩ; amplitude 2V [p-p],
		Output: impedance 600Ω; amplitude 2V [p-p]
	Network	1 RJ45 10M/100M Base-TX Ethernet
<b>General</b>	Power	DC 12V±25%, PoE (IEEE 802.3af)
		Power consumption: Max 7.2W
	Operating Conditions	40°C ~ 60°C (-40°F ~ 140°F), Humidity: ≤95% RH (non-condensing)
	Ingress Protection Level	IP67
	IR Range	30m
	Dimensions	148 x 111.3mm (Ø5.8" x 4.4")

## ACCESSORIES



FCM-ND242  
False Ceiling mount



WM-ND242  
Wall mount



JB-ND242  
Junction Box

## DIMENSIONS

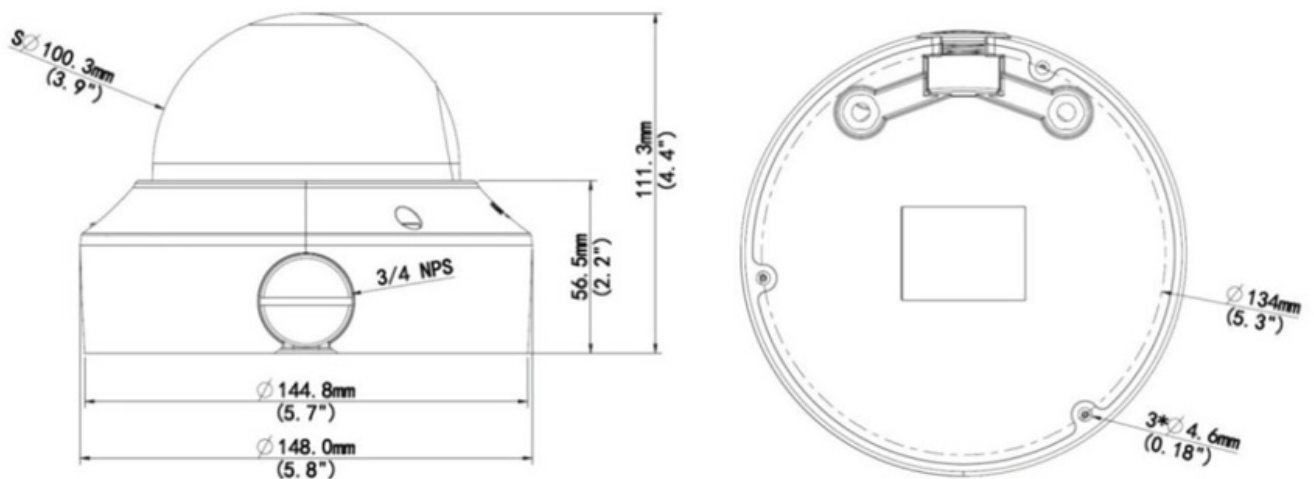

## PARTCODE

TG-ND242Z

## DESCRIPTION

4MP Ultra 265/H.265, 2.8~12mm Motorised dome, 120 dB WDR, 30m IR, IK10, IP67, Triple streams

UAE Address:  
P3-Hamriyah Business Centre  
PO Box 50235  
Hamriyah Free Zone - Sharjah - UAE.  
E-mail: [info@networkvideosolutionsfze.com](mailto:info@networkvideosolutionsfze.com)  
Tel : +97148828919